

# 16W MICRO/LEVEL® WEDGE ISOLATOR SPECIFICATION SHEET

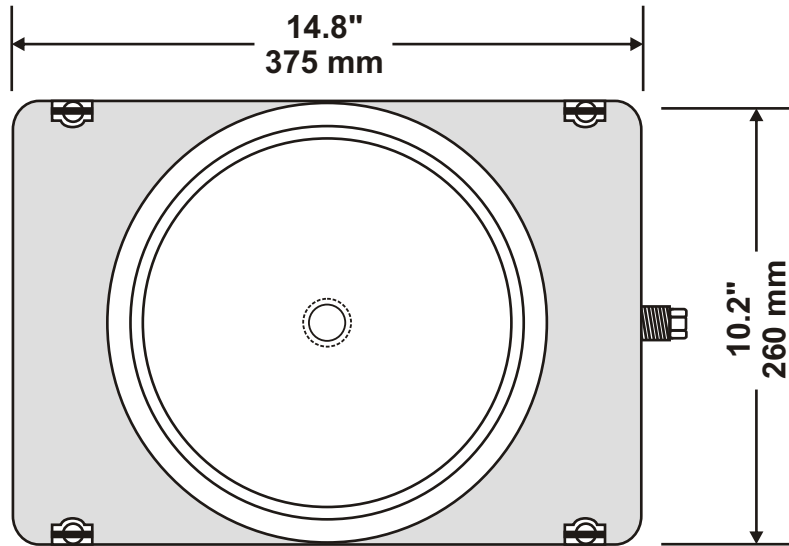

| With Friction Pad |               |                |                            |
|-------------------|---------------|----------------|----------------------------|
| ISOLATOR MODEL    | LOADED HEIGHT |                | Target Installation Height |
|                   | Minimum       | Adjustable To: |                            |
| 16WM40            | 7.0" (178 mm) | 8.0" (203 mm)  | 7.5" (191 mm)              |
| 16WM47            | 7.0" (178 mm) | 8.0" (203 mm)  | 7.5" (191 mm)              |
| 16WL62            | 6.6" (168 mm) | 7.6" (193 mm)  | 7.1" (181 mm)              |
| 16WK72            | 6.4" (163 mm) | 7.4" (188 mm)  | 6.9" (176 mm)              |
| 16WX80            | 6.1" (155 mm) | 7.1" (180 mm)  | 6.6" (168 mm)              |

\* All Dimensional Tolerances are  $\pm 1/8"$  ( $\pm 3.2$  mm)

| With Hold-Down Bolt |               |                |                            |
|---------------------|---------------|----------------|----------------------------|
| ISOLATOR MODEL      | LOADED HEIGHT |                | Target Installation Height |
|                     | Minimum       | Adjustable To: |                            |
| 16WM40              | 7.4" (188 mm) | 8.4" (213 mm)  | 7.9" (201 mm)              |
| 16WM47              | 7.4" (188 mm) | 8.4" (213 mm)  | 7.9" (201 mm)              |
| 16WL62              | 7.0" (178 mm) | 8.0" (203 mm)  | 7.5" (191 mm)              |
| 16WK72              | 6.8" (173 mm) | 7.8" (198 mm)  | 7.3" (186 mm)              |
| 16WX80              | 6.5" (165 mm) | 7.5" (190 mm)  | 7.0" (178 mm)              |

\* All Dimensional Tolerances are  $\pm 1/8"$  ( $\pm 3.2$  mm)

Note: Isolator data subject to change without notice.

Elevation Adjustment per turn of Adjustment Screw - 0.022" (0.56 mm)  
 (Adjustment does not include any changes in elastomer deflection due to changing load)

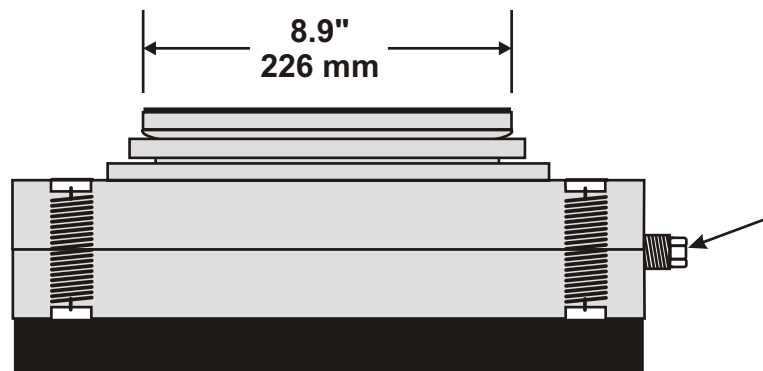

Isolator is furnished with either a friction top pad or an on-center 3/4" or 1.25" hold-down bolt. Off-center hold-down bolt configurations are available as specials.

Leveling Adjustment Screw  
 3/4" (19 mm) head.

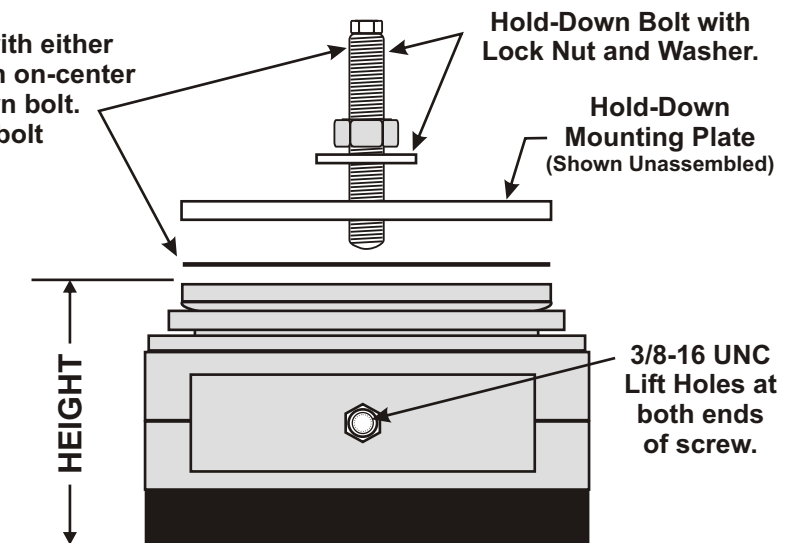

SS-16W 0702