

12W MICRO/LEVEL® WEDGE ISOLATOR SPECIFICATION SHEET

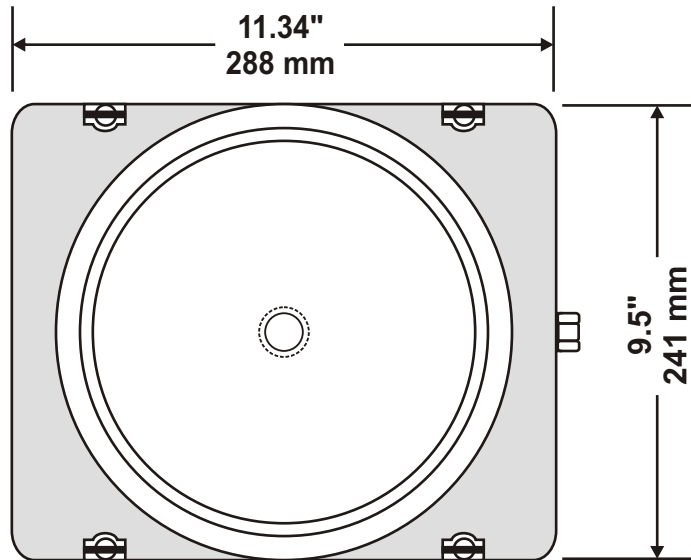

DIMENSIONAL DATA						
Model Number	Loaded Height $\pm 0.125"$ (3.18 mm)				Targeted Installed Height $\pm 0.125"$ (3.18mm)	
	Minimum		Maximum			
	inch	mm	inch	mm	inch	mm
With Hold-Down Plate						
12WM	5.3	135	6.20	157	5.75	146
12WL	4.7	119	5.60	142	5.15	131
12WK	4.3	109	5.20	132	4.75	121
With Friction Pad						
12WM	4.8	122	5.70	145	5.25	133
12WL	4.2	107	5.10	130	4.65	118
12WK	3.8	97	4.70	119	4.25	108

Note: Isolator data subject to change without notice.

Elevation Adjustment per turn of Adjustment Screw - 0.022" (0.56 mm)
 (Adjustment does not include any changes in elastomer deflection due to changing load)

Isolator is furnished with either a friction top pad or an on-center 3/4" or 1.25" hold-down bolt. Off-center hold-down bolt configurations available as specials.

