

VSML2112 HY/SPEED™ SPRING ISOLATOR SPECIFICATION SHEET

ISOLATOR FEATURES

* Integral Leveling	* High Quality Materials
* Material Damping	* Low Stress Design

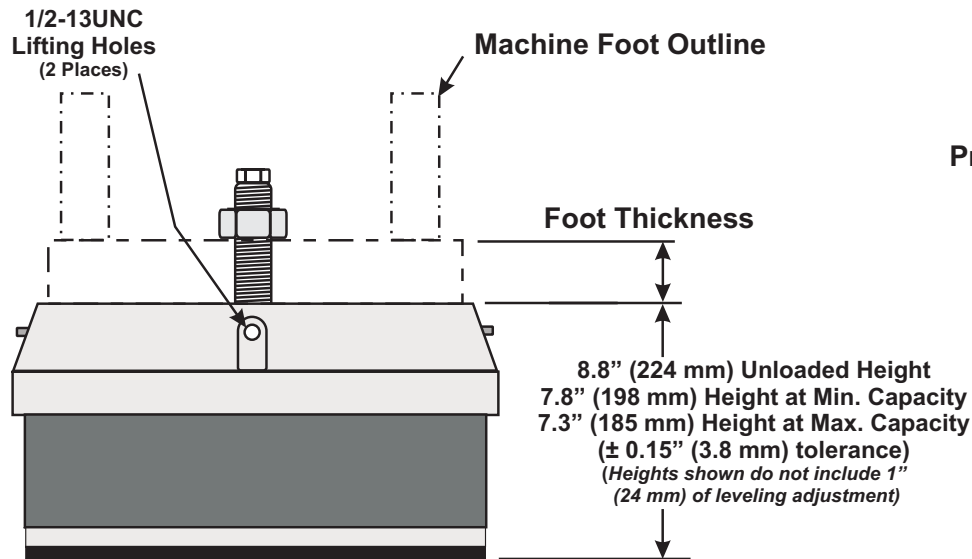
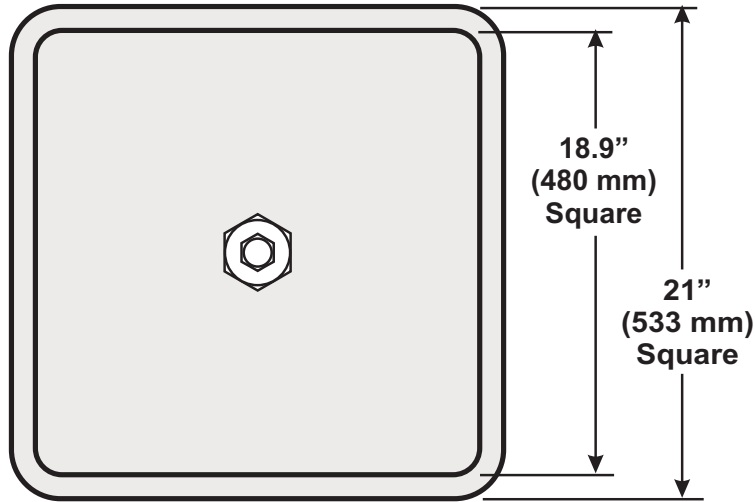

Isolator Model	Maximum Load		Isolator Weight	
	Lbs.	Kg.	Lbs.	Kg.
VSML2112-12000	25,560	11,600	365	166
VSML2112-10020	25,560	11,600	365	166
VSML2112-08040	25,560	11,600	360	163
VSML2112-06060	25,560	11,600	360	163
VSML2112-10000	25,560	11,600	360	163
VSML2112-04080	24,312	11,030	360	163
VSML2112-02100	23,064	10,470	360	163
VSML2112-00120	21,816	9,900	355	161
VSML2112-00102	19,968	9,060	350	159
VSML2112-00100	18,180	8,250	345	156
VSML2112-00082	16,332	7,410	340	154
VSML2112-00080	14,544	6,600	335	152
VSML2112-00062	12,696	5,760	330	150
VSML2112-00060	10,908	4,950	325	147
VSML2112-00042	9,060	4,110	320	145
VSML2112-00040	7,272	3,300	320	145

LEVELING SCREW DATA

Model No.	Pitch	Thread Length	Foot Thickness Up To:
1M	1-14		
1.25M	1.25-12		
1.5M	1.5-12		
1.75M	1.75-12		
2M	2-12		

NOTE: Isolator data subject to change without notice.

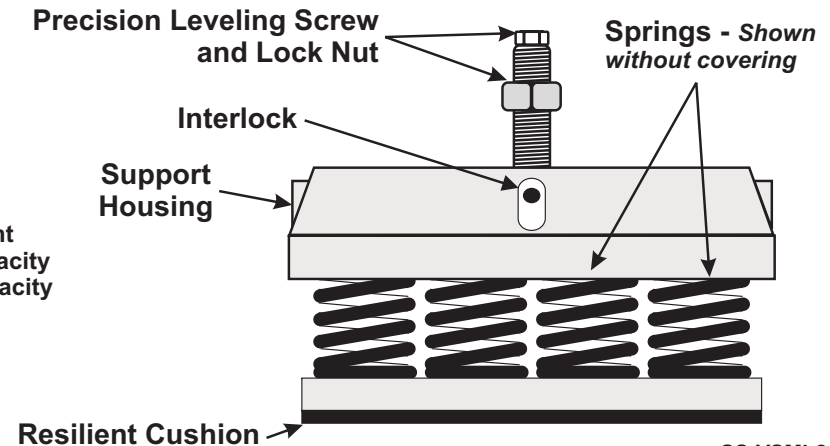

SS-VSML2112 2008.02