

BFM32/33 SERIES MICRO/LEVEL® ISOLATOR SPECIFICATION SHEET

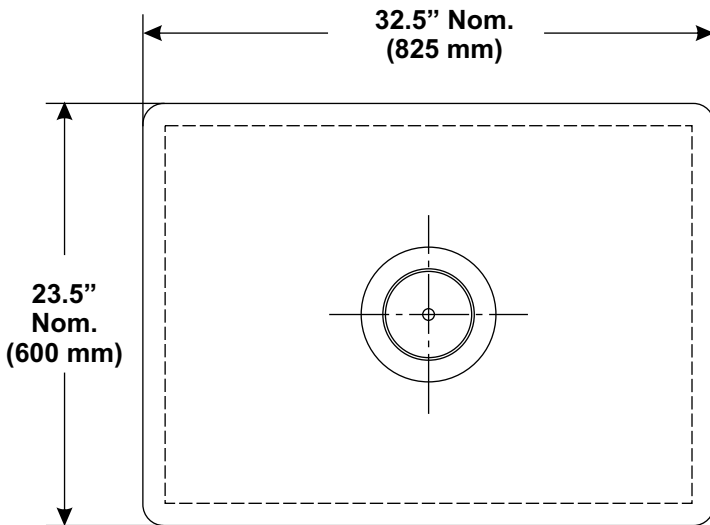

TABLE 1 - Isolator Data Average Ship Weight 1720 lbs./780 Kg.

ISOLATOR MODEL	LOADED HEIGHT				Target Installation Height	
	Minimum		Maximum			
	inch	mm	inch	mm		
BFM32-160	12.4	315	14.4	366	13.4	340
BFM32-190	12.4	315	14.4	366	13.4	340
BFM33-248	14.3	363	16.3	414	15.3	389
BFM33-288	14.1	358	16.1	409	15.1	384

* All Dimensional Tolerances are $\pm 1/8"$ (± 3.2 mm)

TABLE 2 - Leveling Screw Data

Screw Model	Diameter	Thread Length	Good For Foot Thickness Up To:
3.5M	3.50-12		
4.00M	4.00-12		
4.5M	4.50-12		

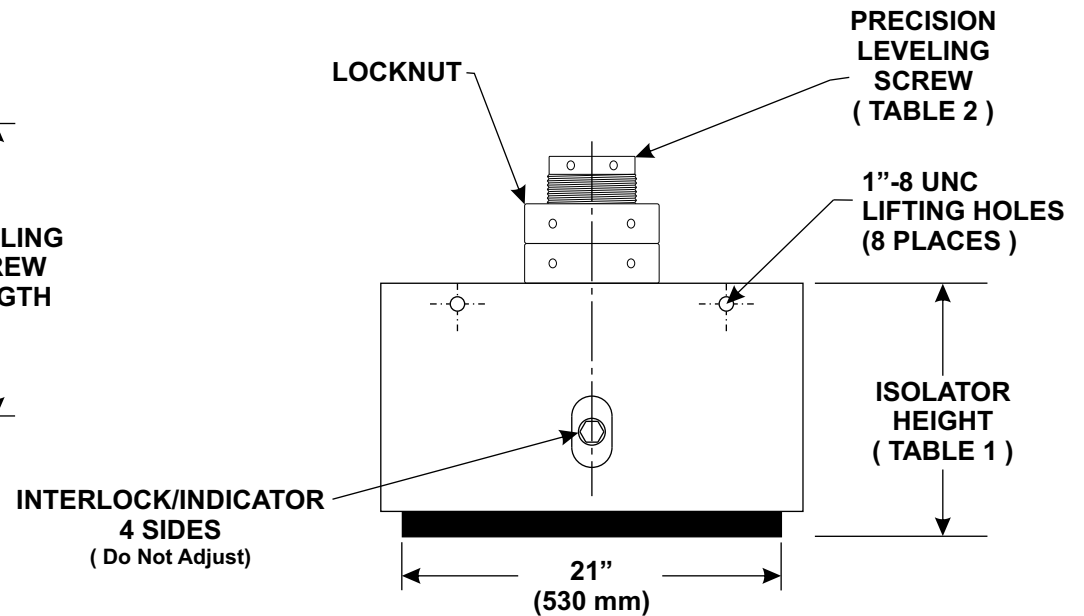
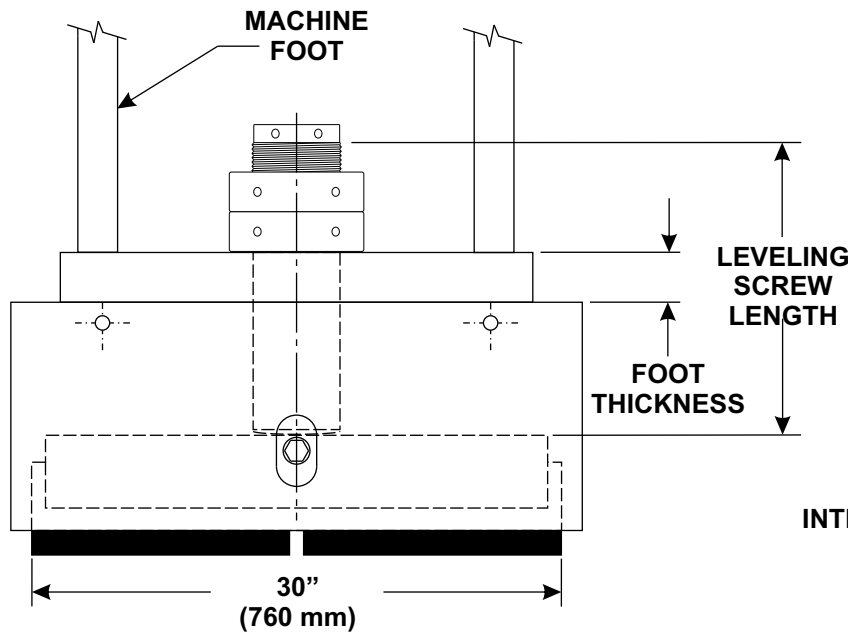

SS-BFM32/33 2004.11