

25MXL MICRO/LEVEL® ISOLATOR SPECIFICATION SHEET

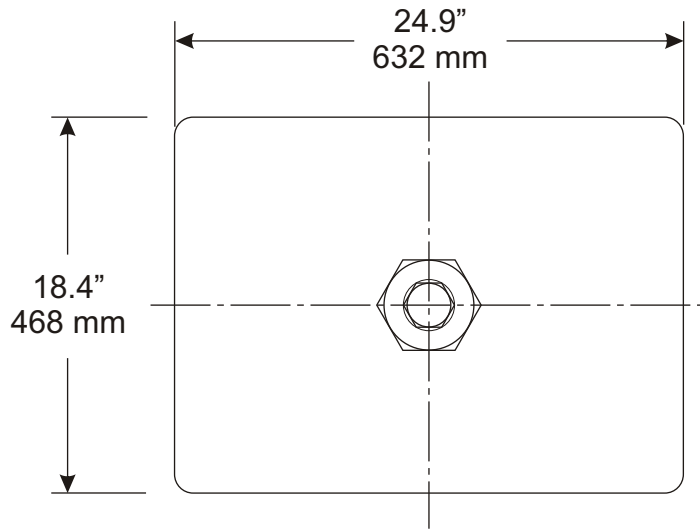

Model Number	Loaded Heights						Targeted Installed Height	
	Minimum		Maximum		Tolerance ±		inch	mm
	inch	mm	inch	mm	inch	mm		
25MXL1441	13.3	338	14.8	376	0.17	4.3	14.1	357
25MXL1442	14.6	371	16.1	409	0.19	4.8	15.4	390
25MXL1443	15.9	404	17.4	442	0.21	5.3	16.7	423
25MXL1444	17.3	440	18.8	478	0.22	5.6	18.1	459
25MXL1601	12.9	328	14.4	366	0.17	4.3	13.7	347
25MXL1602	13.9	354	15.4	392	0.19	4.8	14.7	373
25MXL1603	14.9	379	16.4	417	0.21	5.3	15.7	398
25MXL1604	15.9	404	17.4	442	0.22	5.6	16.7	423

Note: Isolator data subject to change without notice.

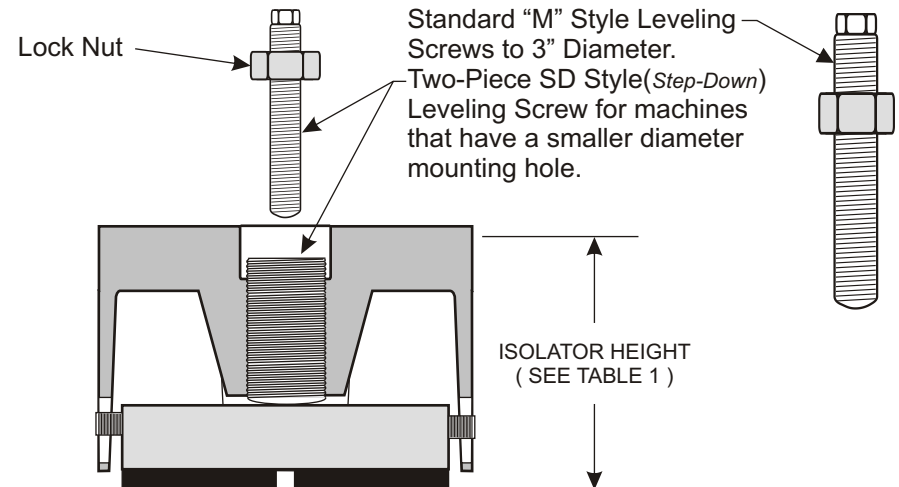
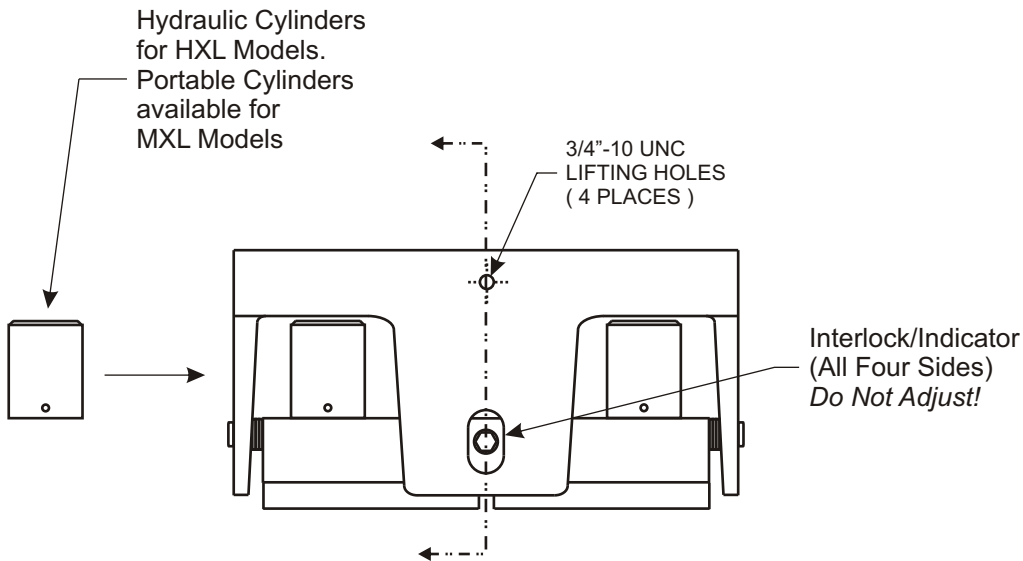

SS-25MXL 2005.06