

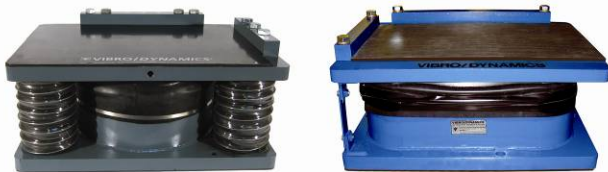

Installation of Forging Hammers on Coil Spring & Elastomeric Isolation Systems

Forging Hammer Isolation

Vibro/Dynamics began producing isolation systems for forging hammers in 2002 after receiving numerous requests for an improved mounting system from hammer builders and forging producers. Vibration and shock isolation of forging hammers is very difficult due to their large masses and extreme shock forces. Vibro/Dynamics first developed the FS Series Coil Spring Isolators with viscous fluid dampers and then followed with the development of the MRM™ Elastomeric Isolation System. Both types have proven to be very effective in isolating hammer and shock forces.



FSV and FSX Viscous Damped Spring Mounts

Coil spring and viscous damper units provide the greatest isolation performance, but have higher initial cost, more expensive foundations, and potential maintenance issues. The viscous dampers in the spring isolators are difficult to protect if a pit should flood; a situation usually requiring the replacement of the damper fluid. Some competitive damper designs have leaked due to the cracks developing in the damper tube walls, which requires the removal and repair of the spring isolators.

As a result, the MRM System has become an accepted standard for vibration and shock isolation around the world. They offer superior isolation performance over timber and pad systems without the larger inertia mass, flooding issues, and higher maintenance cost associated with coil spring isolator systems. They are easy to install and maintain and have proven to be durable.

This document seeks to address the technical issues involved in the isolation of forging hammers. The technical understanding of the isolated hammer system can be best understood at three conditions:

1. When the ram is falling,
2. When the ram is performing work on the part,
3. When the ram rebounds.

When the ram is falling

Hammer capacity is generally rated by the amount of energy that can be delivered by the falling mass, which includes the ram and upper die. Most hammers are designed such that the falling weight starts with zero or near zero initial velocity and impacts the work piece at 6 to 7 m/s (18 to 23 ft/s). It is simple to calculate the hammer's capacity by knowing the maximum falling weight by Equation 1.

$$E = \frac{1}{2} \cdot \frac{w}{g} \cdot v_i^2 \quad (1)$$

The falling mass is calculated by taking the falling weight, *w*, and dividing by one gravity,

g = 9.8 m/s² or 32.2 ft/s². The impact velocity, *v_i*, should be in units of m/s or ft/s. The units of energy capacity, *E*, are N·m = J for metric and ft·lb for imperial measure.

In the case of drop hammers where the falling mass is accelerated by gravity alone, the energy capacity of the hammer may be determined by multiplying the falling weight by the height of the drop, *h*, per Equation 2.

$$E = w \cdot h \quad (2)$$

Some hammers accelerate the falling weight by using a piston powered by steam or pneumatic pressure, or by hydraulic accumulators. These hammers typically hit with higher blow rates. It is important that the isolation system be applied with sufficient damping such that there is no movement when the next blow occurs. If the system is traveling downwards when the next blow arrives, the blow will increase the amplitude of the downward motion more than the prior hit, possibly overstressing the isolation system and building over several blows to an unstable situation. For soft mounting systems and when the falling weight is accelerated by the piston, the hammer's recoil may unload the isolation system, possibly leading to instability. Usually, hammers have sufficient anvil weight so recoil is a minor issue compared to the shock caused by the ram doing work on the part.

When the ram is performing work on the part

The very short time in which the ram contacts the work piece and deforms the work piece is the most important time in the operation for the hammer user. There is a wide range of forging work that can be done in a hammer, so the magnitude of the blow force and the duration of the blow force can vary significantly. Hot open die forging work will impose a lower magnitude and longer duration force between the ram/part/anvil than a hot die forge blow. The finishing blows in die forging operations are the most severe. The analysis of the reaction of the anvil to the blow is actually simplified by the

fact that the anvil is much more massive than the ram and the duration of the impact is very short. The ram travels downward until the anvil velocity is increased to equal the ram velocity, and then it rebounds.

Hammer builders understand that to develop maximum force on the part, the anvil must be much more massive than the ram. Figure 1 shows the theoretical hammer force relative to an extremely massive anvil that is 100 times as large as the ram. Note that once the anvil is more than about 10 times greater in mass, there is little change to the peak force attained.

Maximum Die Force Relative to Anvil Mass 100 Times Falling Mass

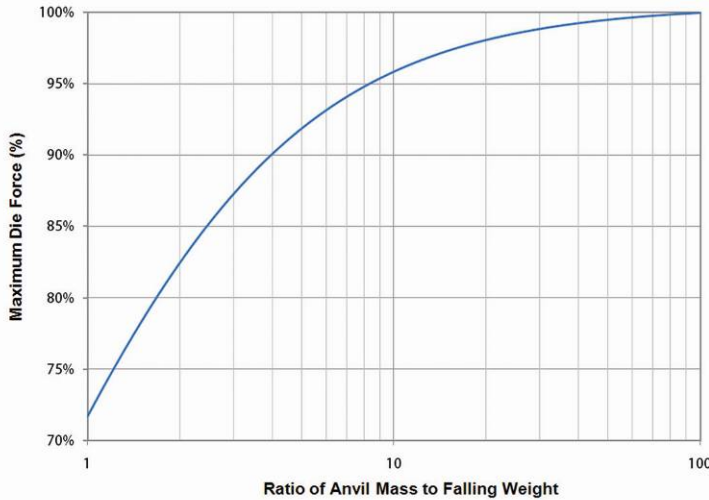

Figure 1

The anvil’s inertia is used to generate the blow force. Softer isolation systems will slightly decrease the peak force of the blow. Both elastomer and spring type isolation systems reduce the available impact force to approximately 99.985% of the force compared with traditional timber support. Because only 0.015% is lost by employing a more efficient isolation system, the benefits to the hammer, foundation, personnel, and nearby equipment easily justify using an economical and reliable isolation system.

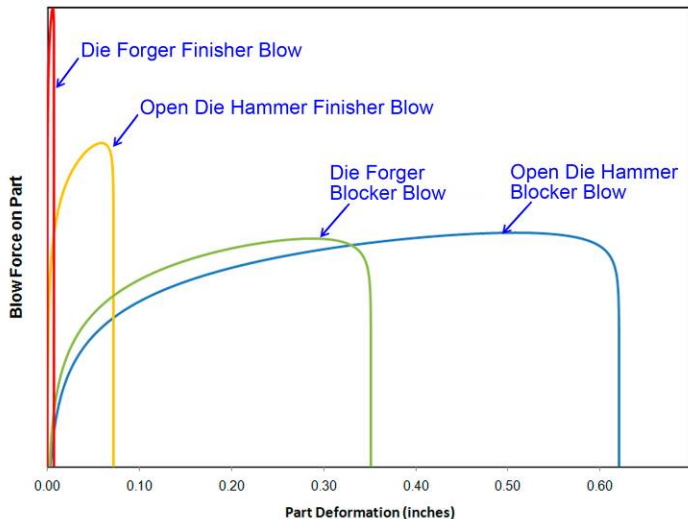

Figure 2

All hammer blows occur over a very short time compared to the oscillations of the anvil after the blow is struck. See Figure 2 for time durations of various blow types. The time for one oscillation of the anvil is the natural period of the hammer system. Traditional hammer support systems using oak timbers may be used as a benchmark for the performance for other isolation systems. Even with timber support, the natural period of the hammer system is much greater than the shock impulse duration of the ram striking the work. The difference results in a significant reduction in the force transferred from the anvil to the foundation. However, because the blow forces are extremely large, even small levels of vibration transmitted to the surroundings may be very disruptive and damaging. In general, the softer the support system, the greater the natural period and the greater the isolation effectiveness. The transmitted shock of the hammer will be reduced if the system natural period is at least six times greater than the shock force duration. Soft systems transmit less vibration to the surroundings than stiff systems.

The collision between the ram and work-piece transfers the momentum of the ram into downward motion of the anvil and the upward rebound of the ram. Once the ram and anvil reach the same velocity the ability of the ram to do work is finished, and the maximum force on the work-piece is achieved. After this point in time, the ram rebounds upwards and the anvil continues to travel downwards.

When the ram rebounds

Once the work has been done on the work-piece and the ram is rebounding, the impact shock from the ram is transferred to the anvil and the isolation system controls the motion and transmitted forces. Because the shock impulse is of very short duration, the hammer system can be accurately modeled by using the conservation of momentum principle. Because some energy is lost in the impact of the ram upon the work-piece, the collision is termed inelastic, but the conservation of momentum laws still apply.

$$m_1 \cdot v_i + m_2 \cdot v_{2i} = m_1 \cdot v_f + m_2 \cdot v_{2f} \tag{3}$$

Where:

- m_1 = ram mass
- m_2 = anvil mass
- v_i = ram velocity immediately before impact
- v_{2i} = anvil velocity immediately before impact
- v_f = ram velocity immediately after impact
- v_{2f} = anvil velocity immediately after impact

The ram will not rebound at the same velocity; this change can be captured in the Coefficient of Restitution, C_R , defined by Equation 4.

$$C_R = \frac{v_{2f} - v_f}{v_i - v_{2i}} \tag{4}$$

Open die forging operations that cause very large deformations in a hot work piece will have very low C_R values of 0.1-0.2. As the work piece cools with very little deformation taking place, as in the case of finishing blows in a closed die forging, C_R values may be as high as 0.5-0.6.

The hammer system can be modeled very effectively as a single degree of freedom system where the supporting isolation material is a simple spring and dashpot as shown in Figure 3. The dynamic stiffness, K , of the isolation system determines the amount of motion and the amount of force transferred to the foundation.

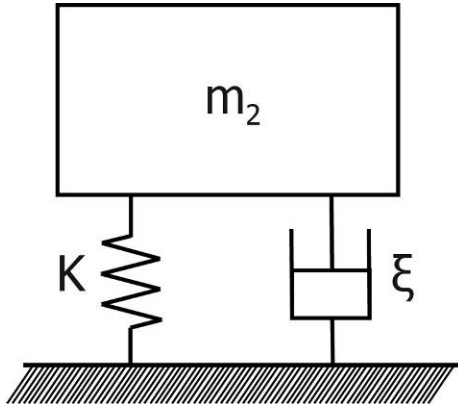

Model for Single Degree of Freedom Hammer System

Figure 3

The damping component, ξ , of the system dissipates energy as heat as the system is brought back to the static state of equilibrium. The damping has little effect on the first downward peak displacement of the anvil, but over several cycles the anvil slows to the at rest state.

After the ram has struck the work piece and the momentum of the ram is transferred to the anvil, the anvil will oscillate about the equilibrium position upon the isolation system at a frequency, called the damped natural frequency of the system, given by Equation 5.

$$\Omega_d = \sqrt{\frac{K}{m_2} \cdot (1 - \xi^2)} \quad (5)$$

From this simple model, the equation describing the vertical motion of the anvil mass, m_2 can be solved as Equation 6.

$$x(t) = \frac{(1+C_R) v_i \left(\frac{m_1}{m_1+m_2}\right)}{\Omega_d} \cdot e^{-\xi \cdot \sqrt{\frac{K}{m_2}} \cdot t} \cdot \sin(\Omega_d \cdot t) \quad (6)$$

Reviewing the variables within Equation 6;

- The motion of the hammer system is reduced when the anvil weight, m_2 , is increased and,
- The motion is increased with a softer, lower natural frequency system, Ω_d .

If a generally accepted limit of 7mm peak motion is applied, then it is clear that for coil spring and elastomeric systems there may be a need for the anvil to weigh more in order to

maintain the natural frequency and isolation performance, as shown in Figure 4.

Because of the cost to add a concrete or steel inertia mass, the

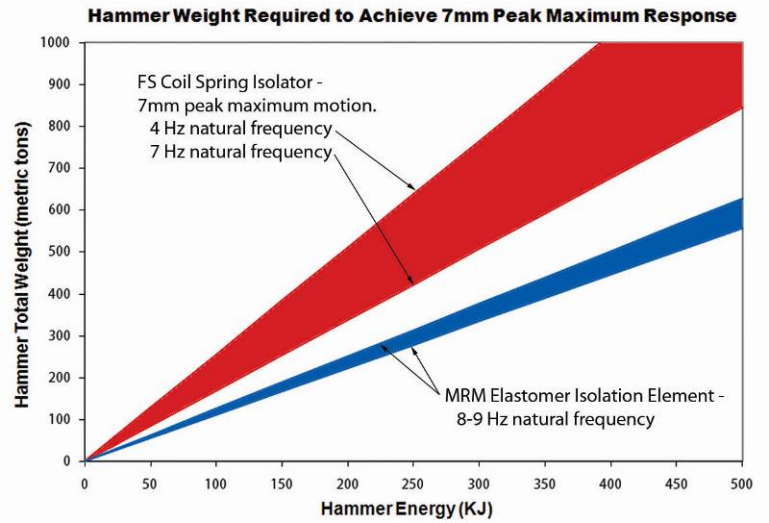

Figure 4

elastomer based MRM system is more economical at the expense of a very small reduction in isolation effectiveness. A steel inertia mass is more economic since a steel plate is more dense and requires less space, thereby reducing the area and size of the foundation, see Figure 5 on the next page. Field installations have proven the steel inertia masses to be more durable.

By Hooke's Law, the force transmitted to the foundation is the product of the isolation system dynamic stiffness, K , and the anvil motion $x(t)$:

$$F(t) = K \cdot x(t) \quad (7)$$

For coil spring isolators, the addition of a viscous damper mechanism adds a small amount of force to the force transmitted by the support springs. For elastomeric designs, the hysteresis damping of the material is included in the real dynamic stiffness.

The forces generated in the die space are enormous. The exact magnitude and time duration are generally not known because measuring the force is not possible. However, experienced hammer operators can easily notice a significant reduction in body and arm fatigue of an isolated hammer compared to a traditionally supported hammer on timbers or thin pad material. The correct application of a well designed isolation system will result in a significant reduction of the ram's enormous impact shock. The MRM System transforms the impact shock from a series of short duration, high magnitude impulses, as shown in Figure 2, to a series of longer duration, smaller magnitude impulses, as shown in Figure 6. Isolation of these impact shocks will decrease health problems, decrease building maintenance, decrease neighbor complaints, and decrease foundation costs.

Figure 5 - Inertia Mass Comparison

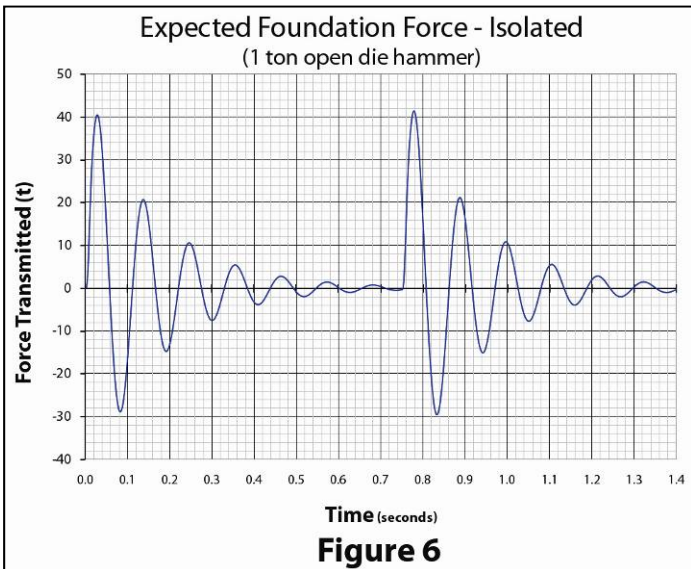
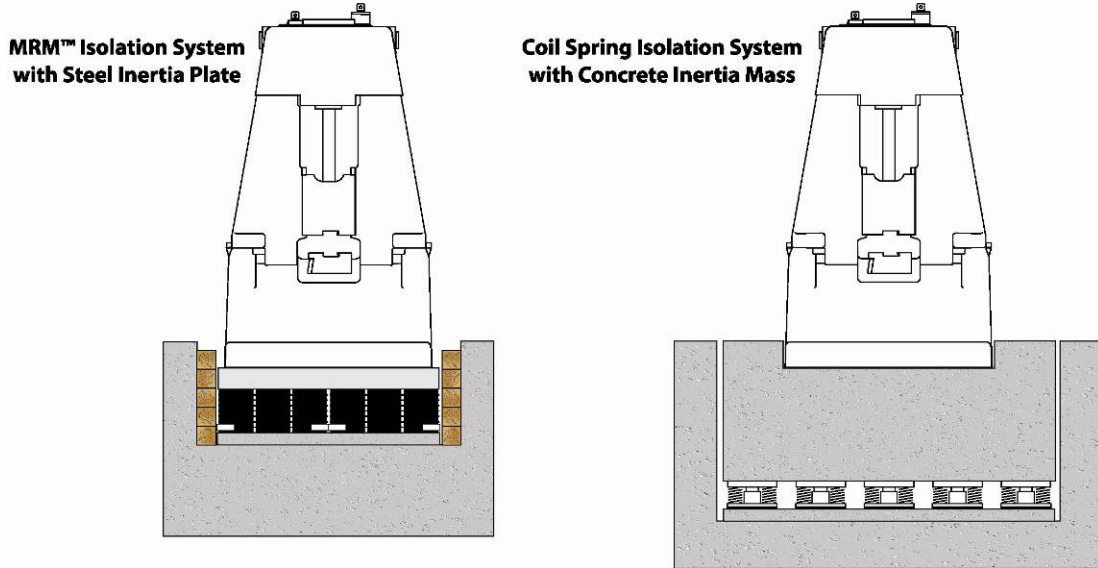

Pre-assembled MRM Isolation Elements are simply lowered into the foundation as complete units. All Elements are identical, eliminating the chance of misplacement. No difficult and time-consuming locating, arranging and stacking of pads and plates in the pit is required! Installations take only a few hours - not days!

Summary

The MRM™ Elastomeric Isolation System has proven to be a very effective for forging hammers. Its isolation performance approaches that of coil spring systems, yet it is more economical and durable.

When compared to traditional forge hammer installation methods, like timbers and rubber pads, the isolation performance of MRM Systems is clearly superior, yet it's faster and easier to install due to its unitized construction. See Vibro/Dynamics M/L Bulletin 710 for vibration isolation comparisons.

Since Vibro/Dynamics Corporation has the technology and know how to design and build both MRM Elastomer and FS Spring Mount Isolation Systems, we are in the best position to recommend an isolation system that best fits your needs.

MRM™ Isolation Element Construction

MRM™ Isolation Elements are specially designed for die forgers and drop hammers. This revolutionary new product has the simplicity of a layered elastomer system, with shock isolation effectiveness similar to viscous damped coil spring isolators. Vertical dynamic natural frequencies as low as 8 Hz are achievable, resulting in isolation efficiency as high as 75% compared to traditional oak timbers.

The MRM System design features unitized construction. Each Element is constructed using alternating layers of custom elastomer modules and steel sheets. The elastomer modules are molded from proprietary compounds for superior shock isolation, durability, and ageing and creep resistance. The entire assembly is protected from pit debris by using a durable, closed cell "barrier foam" that encapsulates the modules.

