

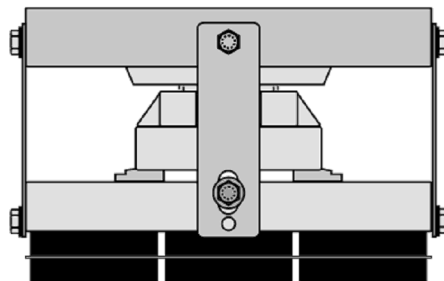

Installation and Leveling Instructions for MXLP Micro/Level® Isolators

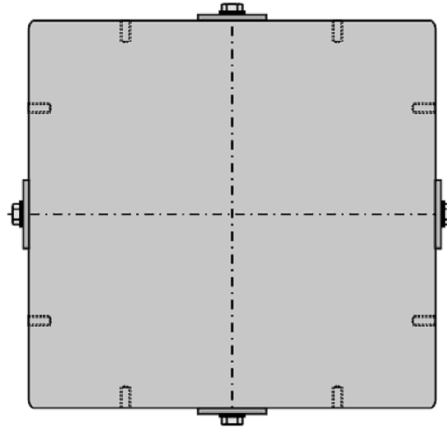

Vibro/Dynamics Technologically Advanced Machinery Mounting Systems are an investment in productivity and efficiency. To realize the full potential of your investment, familiarize yourself with these instructions and use them as a reference during the installation.

The way that your machine is installed has a significant effect on its performance. The four conditions required for a good machine installation and best performance are:

- machine bed in one plane (level)
- precise alignment and parallelism of machine structure
- proper support
- effective control of vibration.

Vibro/Dynamics Isolators make it possible to accomplish all of these steps to an ultra-high degree of precision and to do so very quickly. When the machine is fine-tuned and leveled, the machine will produce high quality parts with minimum wear and tear on dies and machine components. Downtime, noise, and vibration will be reduced, and productivity and efficiency will be increased.

INSTALLATION AND LEVELING INSTRUCTIONS

Preparation

1. It is highly recommended that the foundation be designed using the tips and suggestions per *Vibro/Dynamics M/L Bulletin 703-1 Foundation and Pit Design Guidelines*, which will make isolator installation, press leveling and alignment, and future maintenance faster and easier.
2. The concrete surface under the isolator must be clean, flat, and trowel finished. There should not be any holes, cracks, or lumps directly under the isolator. Patch all holes and broken concrete. Epoxy grout is recommended for concrete repair.
3. Clean and inspect the machine feet and legs. Repair any cracks or damage. The bottom of the machine feet must be clean and flat where it contacts the top of the isolators. Clean all debris from the mounting holes.

Installation

4. MXLP Isolators can be installed using one of the three following methods.

One, if a machine is already in place; the isolators can be slid under the machine feet.

Two, if the isolators have been provided with optional attachment bolts; then the isolators can be attached to the press bed and then lowered into the pit with the press bed.

Three, the isolators can be placed on the foundation piers, sighted in to rough level, and then the press lowered on top of the isolators.

5. If the isolators are equipped with attachment bolts, position each isolator so there is uniform clearance between the threaded hole in the isolator and the inside surface of the mounting hole (see Figure 1). Any contact between the attachment bolt and the inside surface of the mounting hole as it is turned into the isolator housing can cause the attachment bolt to jam.
6. Tighten the attachment bolt lock nuts.
7. Depending on which installation method is being used (Step 4), carefully lower the machine on top of the isolators or raise the isolator up to the machine foot.

- For isolators not using an attachment bolt, insert the friction pad between the isolator and the press foot.
- For isolators using an attachment bolt, make sure that no metal chips or debris fall into the threaded hole in the isolator, which may cause the attachment bolt to jam.

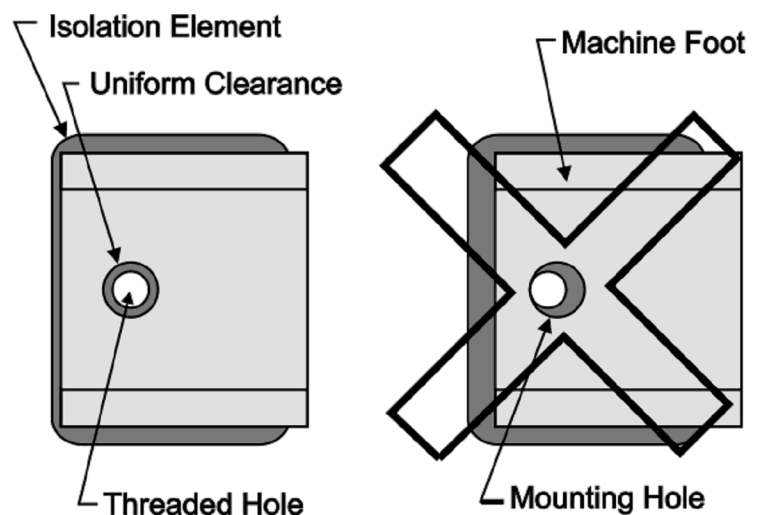

FIGURE 1

8. For proper performance, the Isolator Support Housing and Bearing Plate must be centered and aligned as shown in Figure 2. The isolator is equipped with shipping straps and bolts to maintain alignment between major isolator components during the handling and installation of the isolator.

9. If the elastomer and bearing plate subassembly require centering, then the elastomer and bearing plate subassembly can be repositioned on the concrete surface using a hydraulic jack. See Figure 3.

Note: Re-centering of isolator components is not likely if shipping straps and bolts are kept in place during handling and installation of the isolators.

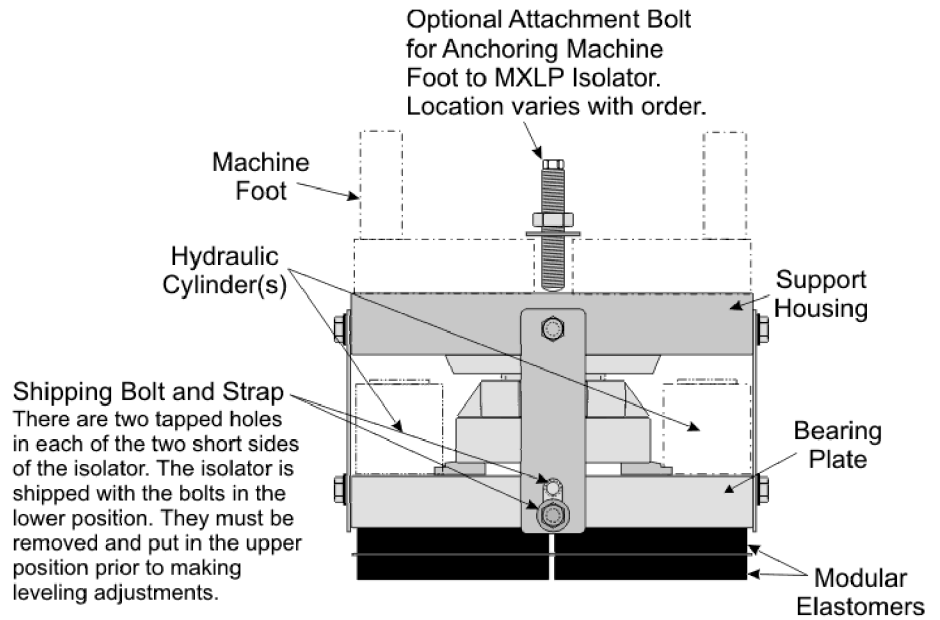
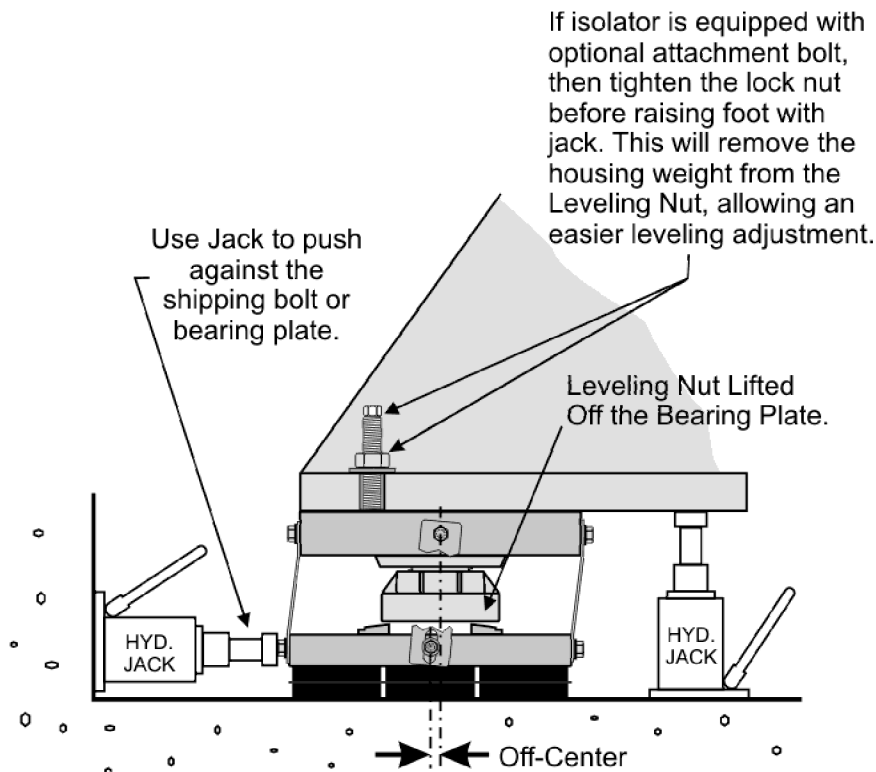

FIGURE 2



If isolator is equipped with optional attachment bolt, then tighten the lock nut before raising foot with jack. This will remove the housing weight from the Leveling Nut, allowing an easier leveling adjustment.

FIGURE 3

Leveling

10. Refer to the machine manual for the machine's leveling locations and tolerances.
11. Relocate the shipping bolts. There are two tapped holes in the Bearing Plate in each short side of the isolator. For shipping and handling, the shipping bolts are located in the bottom holes. The bolts *must* be relocated from the bottom holes to the top holes prior to making leveling adjustments. See Figure 2.
12. To make leveling and elevation adjustments, the load supported by the isolators must be removed. This can be achieved using an overhead crane, a gantry, or hydraulic jacks. It can also be achieved by placing hydraulic cylinders internally within the isolators.

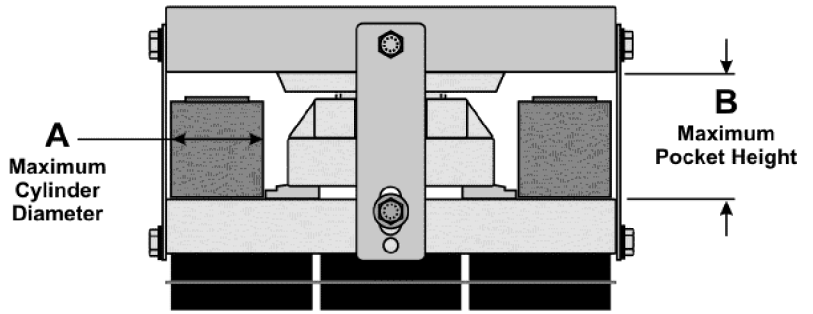

Hydraulic Cylinder Specifications										
Isolator Model Number Prefix	Required Lifting Capacity		Enerpac® Cylinders				Cylinder Dimensions (maximum)			
			Standard		Low Height		A Diameter		B Height	
			Qty.	Standard	Qty.	Low Height	inches	mm	inches	mm
30 MXLP	93	0.83	2	RCS-502	2	RSM-500	9.3	237	8.9	227
31 MXLP	108	0.96	4	RCS-502	2	RSM-1000				
33 MXLP	124	1.10	4	RCS-502	4	RSM-500	8.8	224	8.3	211
34 MXLP	144	1.28	4	RCS-502	2	RSM-1000				
35 MXLP	186	1.66	4	RCS-502	4	RSM-500	9.5	242	8.63	220
36 MXLP	216	1.92	4	RCS-1002	4	RSM-1000				
44 MXLP	248	2.21	4	RCS-1002	4	RSM-1000	14	356	8.3	211
46 MXLP	288	2.56								
48 MXLP	279	2.48	4	RCS-1002	4	RSM-1000	14	356	8.3	211
50 MXLP	320	2.85								

- If internal hydraulic cylinders are used, refer to the Hydraulic Cylinder Specifications for MXLP Isolators Table for cylinder size and capacity information.
 - Two or four cylinders are required per isolator. The cylinders within the isolator should be hydraulically connected. This equalizes the hydraulic pressure within the isolator for uniform lifting and loading of the isolator's elastomer cushion. See Figure 4.
13. The isolators are supplied with the height adjustment set at mid-level. Leveling is accomplished by turning the large Leveling Nut located inside the isolator. Viewed from above, turn the leveling boss clockwise to raise the isolator, and counter-clockwise to lower it. See Figure 4.
 14. The Leveling Nut can be turned using a 1" (24 mm) open-end wrench per Figure 5. Horizontal access to the isolators is required.
 15. Using a precision machinists' level, electronic level, or laser, determine the machine's low side in the left-to-right direction. Raise all of the isolators on the low side an *equal* amount until the machine is level in that direction.
 16. Repeat procedure in the front-to-back direction.
 17. Repeat the above Steps until the machine is level.
 18. The isolators should not be over-adjusted to compensate for extreme out-of-level floor or foundation condition. Use the slot in the Shipping Straps can be used as an adjustment guide. Consult Specification Sheets for isolator height ranges. If a severe out-of-level condition exists, a spacer plate can be inserted between the isolator and the machine foot.

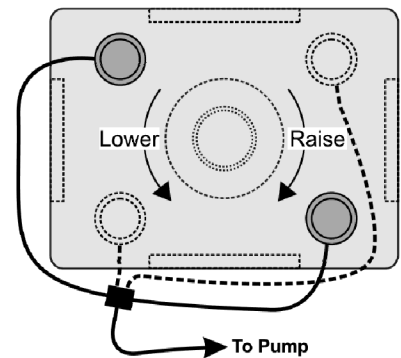

FIGURE 4

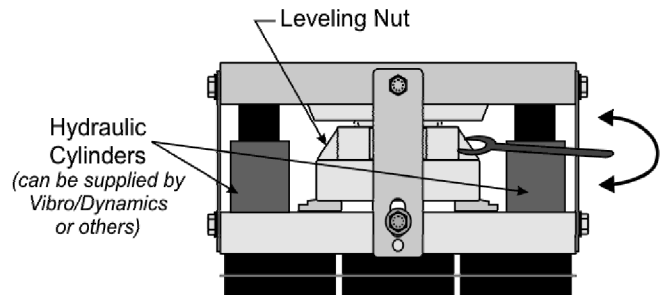

FIGURE 5

Elevation

19. MXLP isolators can have up to four layers of resilient members. The more layers an isolator has, the more time it will take the isolator to “settle out” and the elevation to stabilize. Upon request, a graph showing “elastomer deflection vs. time” can be provided when the elevation of a machine is critical, such as in rolling bolster installations. The deflection graph can be used as a guide when stacking a large press. The press bed can be initially set high to offset additional weight and settling as the press is being assembled.

Additional Considerations

20. A rust proofing formulation should be applied to the isolator leveling and attachment screws if a machine is frequently washed-down with a water-based solution. Rust can cause the screws to jam over time.
21. There should not be any solid connections between the machine and the foundation or building structure. Flexible connections are recommended for all plumbing and electrical conduit. Floor plates, walkways, railings, feeds, rolling bolster rails, etc. should *not* be attached to *both* the machine and the floor, foundation or building. Rigid connections will “short-circuit” isolation effectiveness. (See Figure 6).

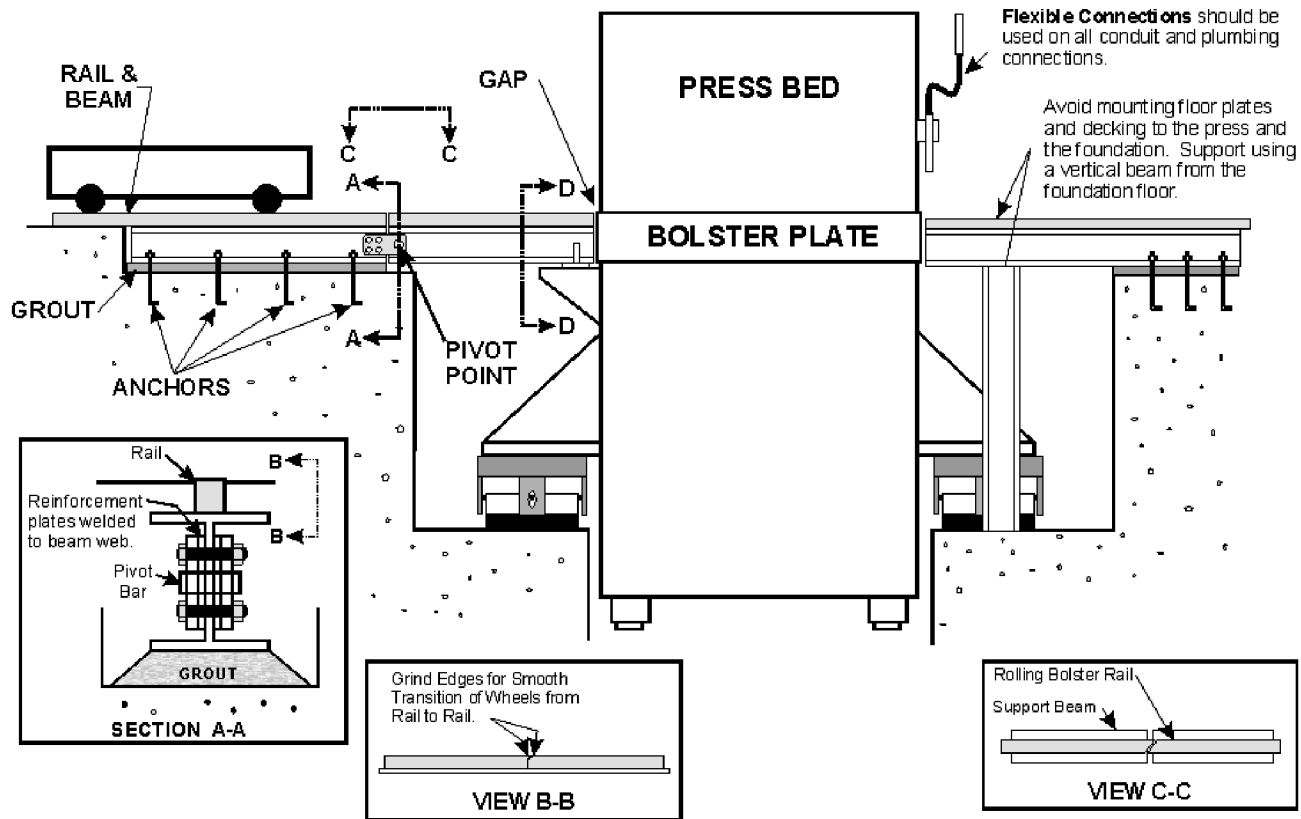

FIGURE 6

Caution: Vibro/Dynamics Isolators do not bolt to the floor and should not be used to mount machines that depend on anchor bolts to keep them from tipping or collapsing.

Call or write for assistance:

VIBRO/DYNAMICS Corporation

2443 Braga Drive, Broadview, IL 60155-3941

E-Mail: vibro@vibrodynamics.com

www.vibrodynamics.com

1-800-842-7668 (USA only)

1-708-345-2050 Telephone

1-708-345-2225 Fax

Vibro/Dynamics®, Micro/Level®, Hydra/Level®, and Hy/Speed® are registered trademarks and Lod/Sen™ is a trademark of the Vibro/Dynamics Corporation. All rights reserved.