

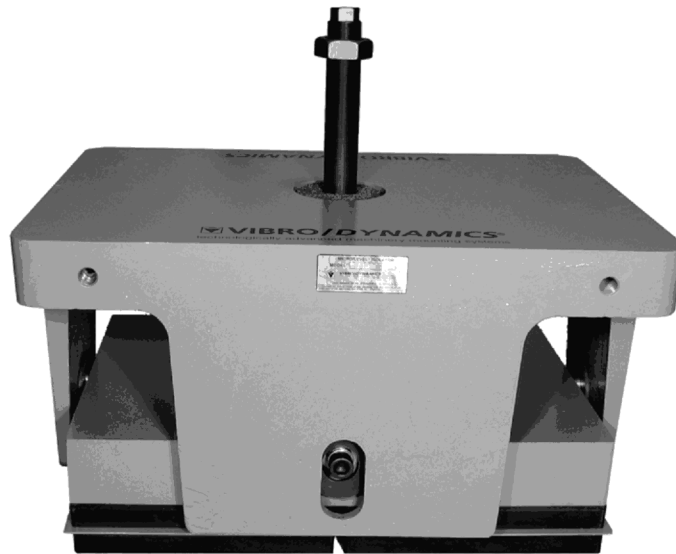

# Installation and Leveling Instructions for MXL & HXL Micro/Level® Isolators

Technical Bulletin M/L – 683



**33MXL Micro/Level Isolator Shown**

Vibro/Dynamics' Technologically Advanced Machinery Mounting Systems are an investment in productivity and efficiency. To realize the full potential of your investment, familiarize yourself with these instructions and use them as a reference during the installation.

The way that your machine is installed has a significant effect on its performance. The four conditions required for a good machine installation and best performance are:

- machine bed in one plane (level)
- precise alignment and parallelism of machine structure
- proper support
- effective control of vibration.

Vibro/Dynamics' Isolators make it possible to accomplish all of these steps to an ultra-high degree of precision and to do so very quickly. When the machine is fine-tuned and leveled, the machine will produce high quality parts with minimum wear and tear on dies and machine components. Downtime, noise, and vibration will be reduced, and productivity and efficiency will be increased.

## INSTALLATION AND LEVELING INSTRUCTIONS

### Preparation

1. See Vibro/Dynamics M/L Bulletin 688 for Foundation and Pit Design Guidelines.
2. The concrete surface under the isolator must be clean, flat, and trowel finished. There should not be any holes, cracks, or lumps directly under the isolator. Patch all holes and broken concrete.
3. Clean and inspect the machine feet and legs. Repair any cracks or damage. The bottom of the machine feet must be clean and flat where it contacts the top of the isolators. Clean any debris from the mounting holes.

### Installation

MXL Isolators come equipped with two different leveling screws styles: “M” standard style and “SD” two-piece style. To determine which style screws were provided with the MXL isolators; refer to the second set of alpha/numeric figures in the isolator’s model number (i.e. 24MXL1441 2.5M14 or 24MXL1441 2.5SD14)

1. MXL Isolators are usually installed using one of the following methods. *One*, if a machine is already in place; the isolators can be slid under the machine feet. *Two*, if the machine is being rigged; the isolators can be attached to the machine base outside the pit and then lowered into the pit as a unit.
2. Position each isolator under the machine foot so there is uniform clearance between the threaded hole in the isolator and the inside surface of the mounting hole (see Figure 1). Any contact between the leveling screw and the inside surface of the mounting hole as it is turned into the isolator housing can cause the leveling screw to jam.
3. Depending on which installation method is being used (see Step 1), carefully lower the machine onto the isolator or raise the isolator up to the machine foot, making sure that no metal chips or debris fall into the isolator’s threaded hole. This may cause the leveling screw to jam.
4. Refer to one of the two following sections for additional installation details depending on leveling screw style.

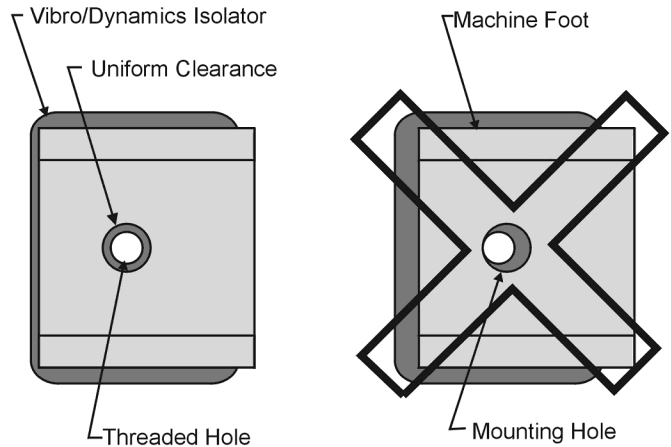

**Figure 1**

### MXL Isolators with “M” Style Leveling Screws

1. Remove the orange protective plug from the tapped hole if supplied with the isolator.
2. Thread the “M” style leveling screw into the isolator by hand or with a small wrench. The leveling screw should turn easily into the isolator housing until it contacts the internal bearing plate (see Figure 2). If it does not, remove the leveling adjustment screw and check for proper clearance, damaged thread, or debris in the threaded hole.
3. When the leveling screw contacts the bearing plate, turn the leveling screw two additional turns. Hydraulic cylinders may be necessary to remove weight in order to turn the leveling screw. Place a minimum of two appropriate size cylinders, diagonally opposed from each other, on top of the bearing plate as shown in Figure 2. Do not use wrench extensions or a hammer to force the leveling screw to turn.

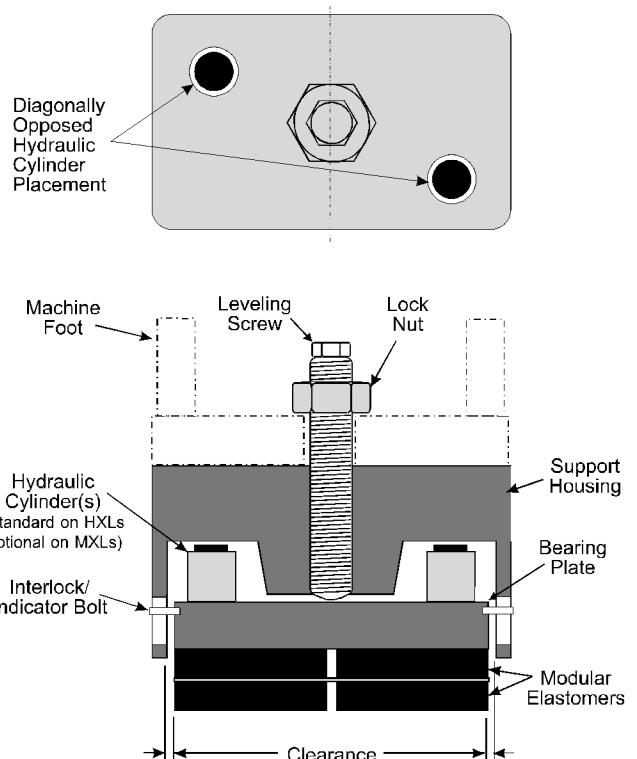
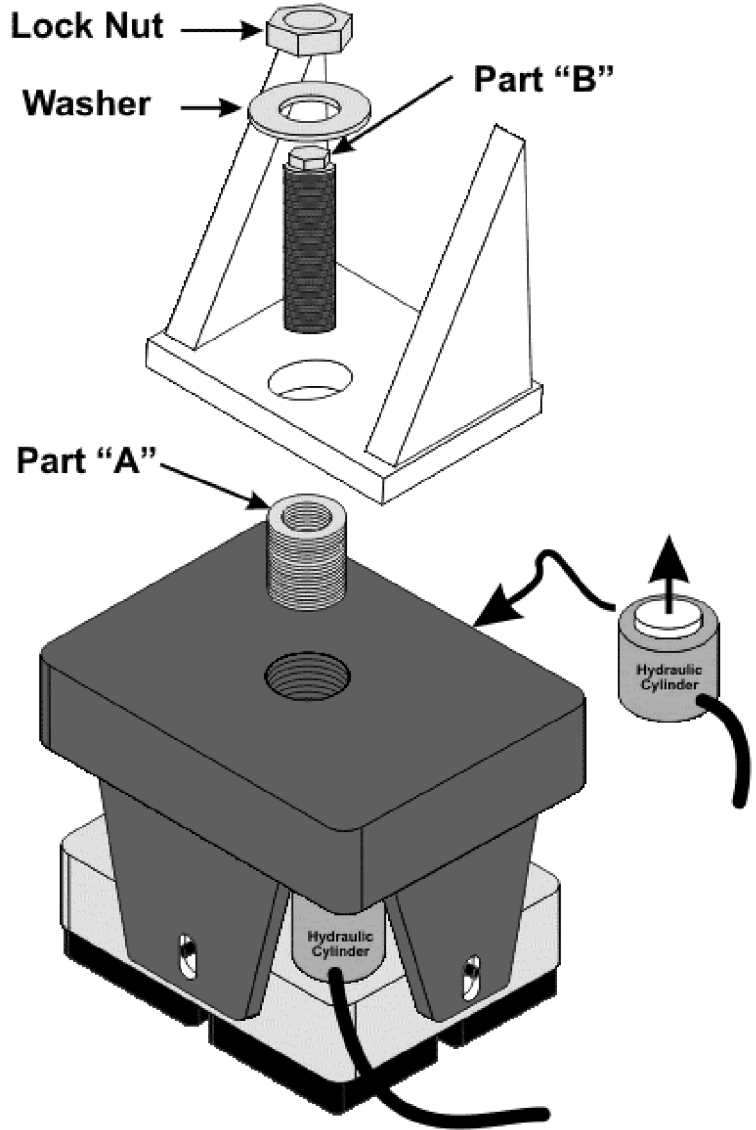

**Figure 2**

**MXL Isolators with "SD" Style Leveling Screws**

"SD" leveling screws have two parts. Part "A" of the Leveling Screw is factory installed in the isolator. Part "B" is packaged separately.

1. Remove the orange protective plug from the tapped hole if supplied with the isolator.
2. Do not remove the black protective foam from the mounting hole. This acts as a protective device to keep debris from collecting around the leveling screw.
3. Apply a small amount of thread locking compound (Loc-Tite® or other) to the starting threads of Part "B".
4. Insert Part "B" through the machine's mounting hole and then thread into Part "A" of the leveling screw until tight.
5. Remove load from isolator.
6. Turn the leveling screw into the isolator's housing until it bottoms on the isolator's internal bearing plate. See Figure 2.
7. Turn the leveling screw two additional turns.



**All MXL Isolators**

1. For proper isolator performance, there must be clearance between the resilient cushion (elastomer) and the inside surface of the isolator's support housing as shown in Figure 3. If there is not clearance, lift the machine at that location and center the resilient cushion in the isolator housing.
2. MXL and HXL isolators are equipped with four Interlock/Indicator bolts. These serve as a quick check for centering the resilient cushion. The Interlock/Indicators should be centered side-to-side in the interlock slots as shown in Figure 3A. If the resilient cushion is not centered, the Interlock/Indicators appear as shown in Figure 3B.

**Correct!**

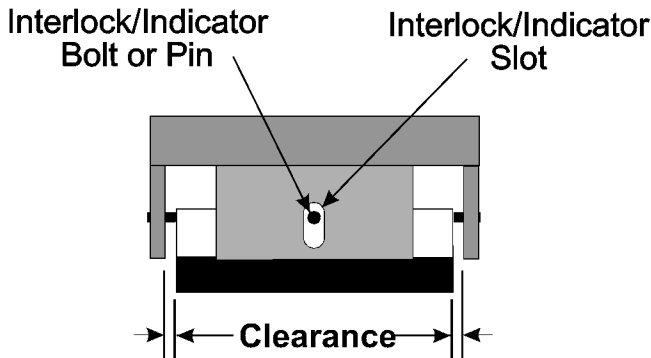

**Figure 3A**

**Wrong!**

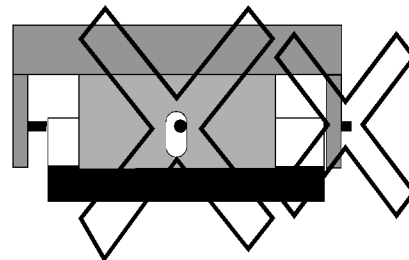

**Figure 3B**

### Leveling

1. Loosen the isolator's locknuts if tight.
2. Refer to the machine manual for the machine's leveling locations and tolerances.
3. Using a precision machinists' level, electronic level, or laser, determine the machine's low side in the left-to-right direction.
4. Remove the load supported by the isolators on the low side using an overhead crane, external hydraulic jacks, or hydraulic cylinders installed internally within the isolators.

- If internal cylinders are used, refer to the Table for cylinder size and capacity information.
- Two or four cylinders are required per isolator. The cylinders within the isolator should be hydraulically connected to one another to equalize the hydraulic pressure within the isolator for uniform lifting and loading of the isolator's elastomer cushion. See Figure 4.

5. Raise all of the isolators on the low side an *equal* amount until the machine is level in that direction.
6. Repeat procedure in the front-to-back direction.
7. Repeat Steps 3 to 6 until the machine is level in all directions.
8. Isolators should not be over-adjusted to compensate for extreme out-of-level floor or foundation conditions. If a severe out-of-level condition exists, a spacer plate can be inserted between the isolator and the machine foot.

**Note:** The Interlock/Indicators on MXL and HXL Isolators can be used to quickly determine the amount of leveling adjustment available.

Figure 5 shows an isolator that has reached its maximum leveling adjustment.

### Elevation

9. MXL & HXL isolators can have up to four layers of resilient members. The more layers an isolator has, the more time it will take the isolator to "settle out" and the elevation to stabilize. Addendum instructions and a chart showing "resilient cushion deflection vs. time" may be provided when the elevation of a machine is critical, such as in rolling bolster installations. The machine should be set high to offset settling when an elevation with accuracy tighter than  $\pm 0.040"$  ( $\pm 1$  mm) is required.

**Note:** Rolling bolster rails must *not* be rigidly fixed to the machine (see Figure 6 and Additional Considerations section) and should not be set until the final machine elevation is determined.

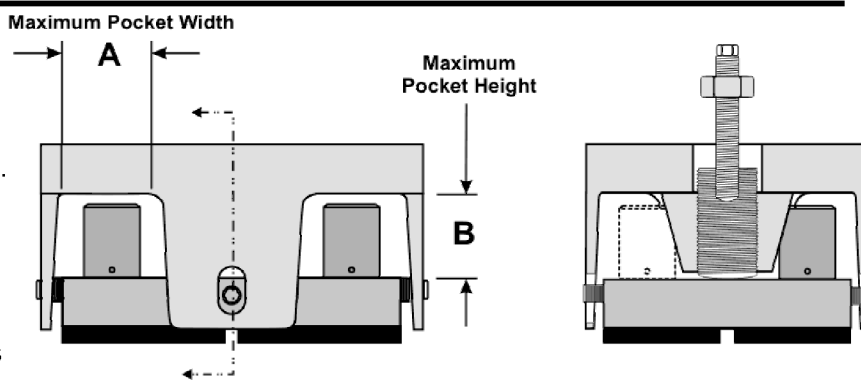

Isolator Model Number Prefix	Cylinder Capacity		Required Number of Cylinders	Fluid Req'd. per Isolator		Pocket Dimensions			
						A		B	
	US Tons	MN		Gal.	Liter	Width		Height	
						inches	mm	inches	mm
24MXL	30	0.27	2	0.14	0.53	6.0	152	5.13	130
25MXL	50	0.44	2	0.16	0.61				
30MXL	50	0.44	2	0.16	0.61	14.7	373	7.7	196
31MXL	100	0.89	2	0.44	1.67				
33MXL	100	0.89	2	0.44	1.67	8.5	216	7.35	187
34MXL									
35MXL	100	0.89	2	0.44	1.67	9	229	7.35	187
36MXL			4	0.88					
48MXL	100	0.89	4	0.88	3.33	12.4	315	12.2	310
50MXL									

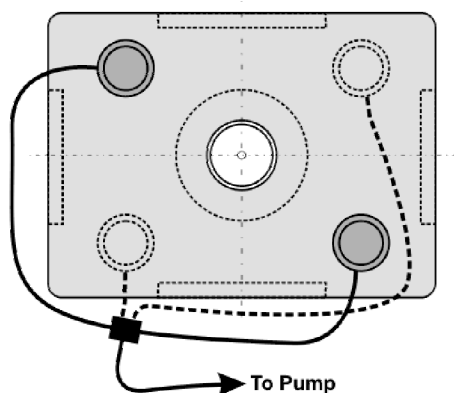

Figure 4

### Isolator Adjusted Too High!

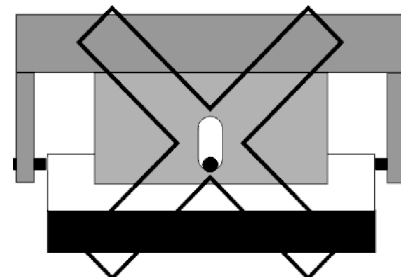

Figure 5

**Tighten Locknuts**

10. Locknuts are provided to fasten the Vibro/Dynamics Isolators to the machine feet. Use a wrench to hold the head of the leveling screw while tightening the locknut.

**Additional Considerations**

- 11. A rust proofing formulation should be applied to the isolator leveling screws if the machine is frequently washed down with a water-based solution. Rust can cause the leveling screw to jam over time.
- 12. There should not be any solid connections between the machine and the foundation or building structure. Flexible connections are recommended for all plumbing and electrical conduit. Floor plates, walkways, railings, feeds, rolling bolster rails, etc. should *not* be attached to *both* the machine and the floor, foundation or building (See Figure 6). Hard connections will “short-circuit” isolation effectiveness.

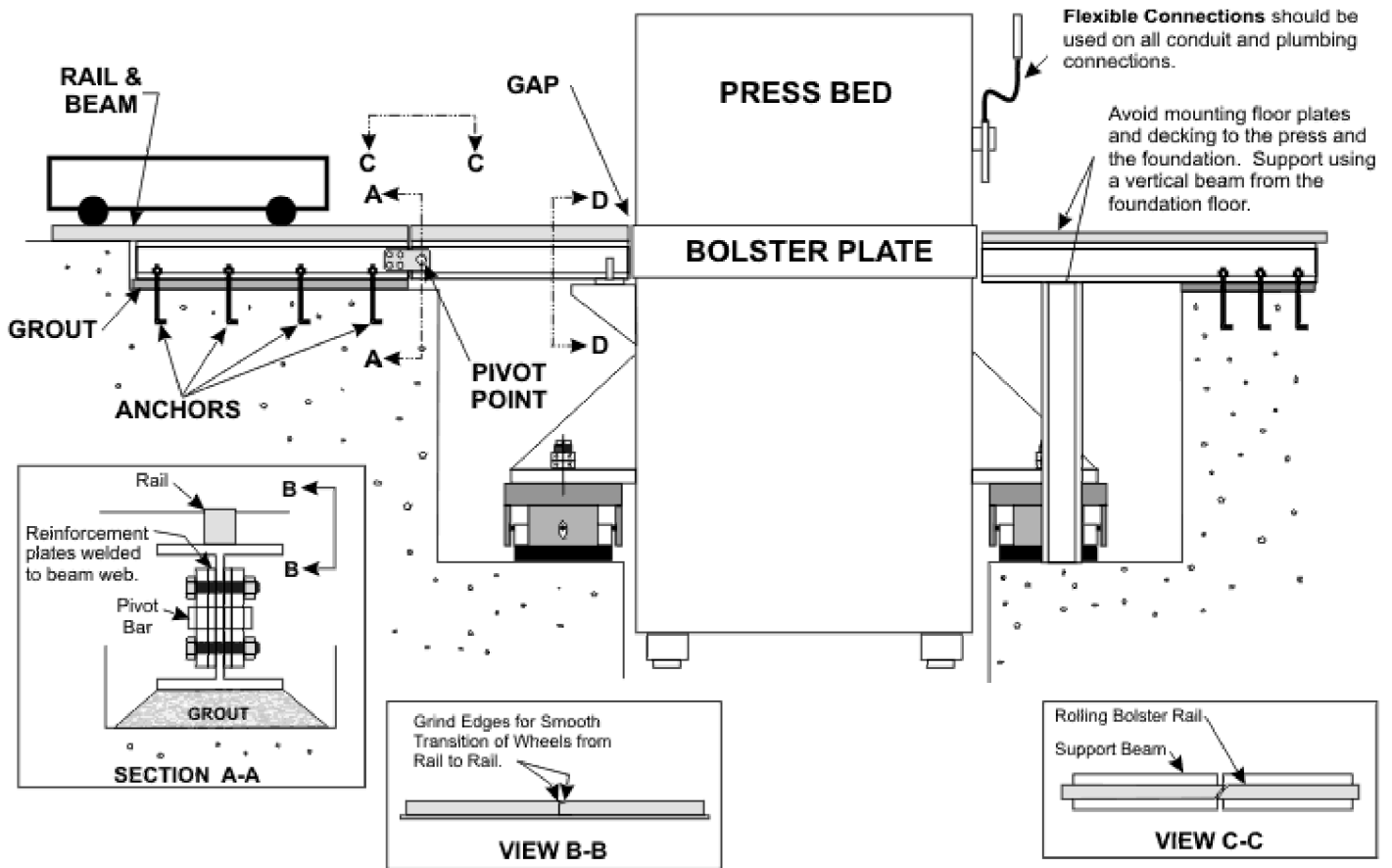

**FIGURE 6**

**Caution:** Vibro/Dynamics Isolators do not bolt to the floor and should not be used to mount machines that depend on anchor bolts to keep them from tipping or collapsing.

**Call or write for assistance:**

**Vibro/Dynamics Corporation**  
 2443 Braga Drive, Broadview, IL 60155-3941  
 E-mail: [vibro@vibroynamics.com](mailto:vibro@vibroynamics.com)  
 Telephone: 1-800-842-7668 (USA only) and 1-708-345-2050  
 Fax: 1-708-345-2225

Vibro/Dynamics®, Micro/Level®, Hydra/Level®, and Hy/Speed® are registered trademarks and Lod/Sen™ is a trademark of the Vibro/Dynamics Corporation. All rights reserved.

**Warranty**

Vibro/Dynamics warrants equipment of its own manufacture to be free from defects in materials and workmanship. This warranty extends only to the original buyer; it is for one year only from the date of sale and is limited to repair or replacement, F.O.B. Vibro/Dynamics' plant, of any original part or component that Vibro/Dynamics finds to have been defective at the time of shipment. Vibro/Dynamics is not liable for consequential damages. This warranty is in lieu of all other warranties, expressed or implied.